

IGD60

Geared Traction Machine

Maximum Full Load Mass : 25,000 KG

Brake Coils : Pick/Hold Voltage : 110/67 VDC

Pick/Hold Current : 3.5/2.13 A

Estimated Weight : 2800 KG

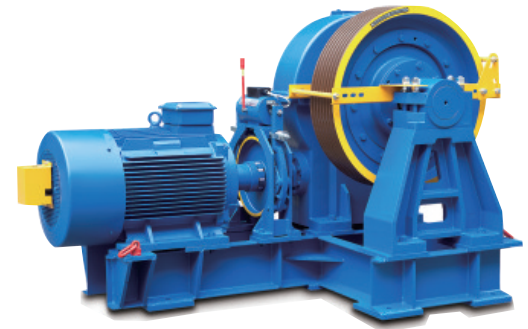

Dimensions in mm

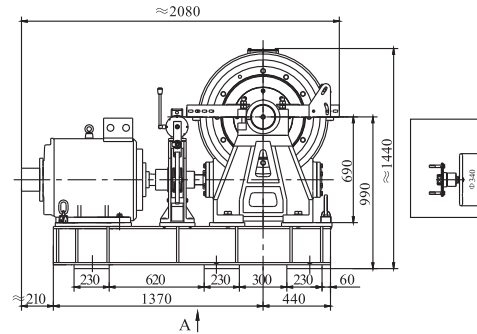
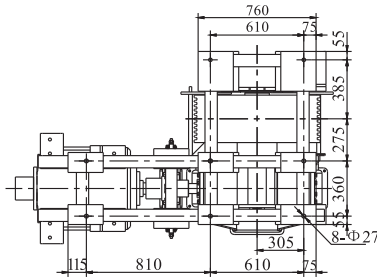

Part Number	Capacity (KG)	Speed (M/S)	Motor (KW)	Pole	Gear Ratio	Power Source (VAC)	Current (A)	Motor Speed (RPM)	Sheave Spec (mm)			
									Dia	Rope#	\varnothing	Pitch
IGD60-551P0-19 mm	5500	1.00	55.0	8	75:2	380	105	886	820	10	19	29

Data are subject to change without prior notice.