

IGD39

Geared Traction Machine

Maximum Full Load Mass: 9,000 KG
 Brake Coils: Pick/Hold Voltage : 110/67 VDC
 Pick/Hold Current : 2.0/1.22 A
 Estimated Weight : 910 KG



Dimensions in mm

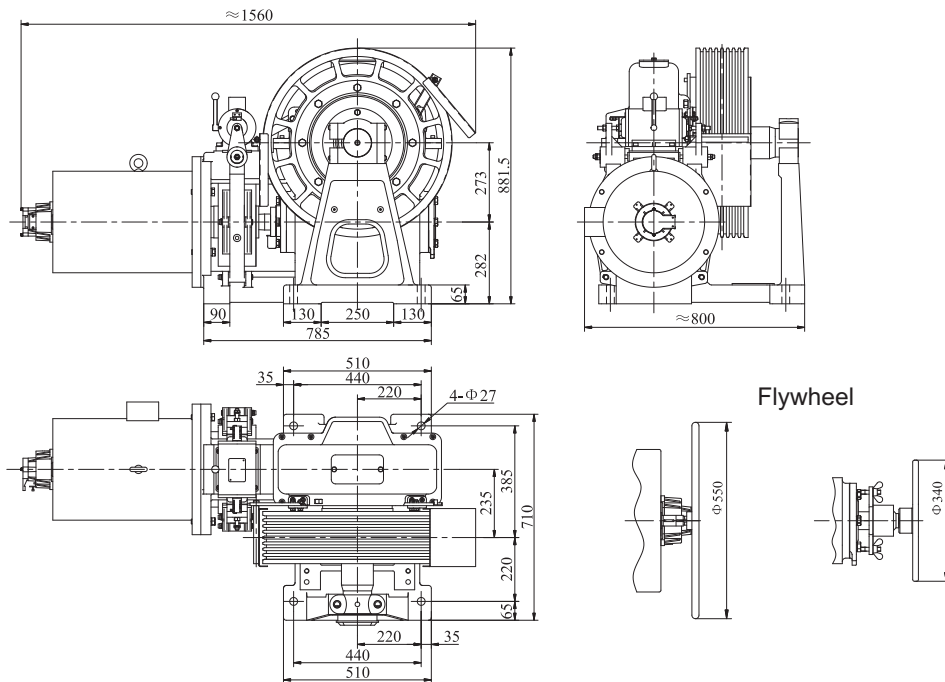

Flywheel

Part Number	Capacity (KG)	Speed (M/S)	Motor (KW)	Pole	Gear Ratio	Power Source (VAC)	Current (A)	Motor Speed (RPM)	Sheave Spec (mm)			
									Dia	Rope#	Pitch	
IGD39-110P5-13 mm	1156	0.50	7.5	6	59:1	380	17	900	650	6	13	20
IGD39-111P0-13 mm	1156	1.00	11	6	59:2	380	25	900	650	6	13	20
IGD39-111P7-13 mm	1156	1.75	18.5	4	57:2	380	35	1440	650	8	13	20
IGD39-112P0-13 mm	1156	2.00	22	4	49:2	380	41	1440	650	8	13	20
IGD39-120P5-13 mm	1224	0.50	7.5	6	59:1	380	17	900	650	6	13	20
IGD39-121P0-13 mm	1224	1.00	15	6	59:2	380	32	900	650	6	13	20
IGD39-121P7-13 mm	1224	1.75	22	4	57:2	380	41	1440	650	8	13	20
IGD39-122P0-13 mm	1224	2.00	26	4	49:2	380	48.5	1440	650	8	13	20
IGD39-130P5-13 mm	1360	0.50	7.5	6	59:1	380	17	900	650	6	13	20
IGD39-131P0-13 mm	1360	1.00	15	6	59:2	380	32	900	650	6	13	20
IGD39-131P7-13 mm	1360	1.75	22	4	57:2	380	41	1440	650	8	13	20
IGD39-132P0-13 mm	1360	2.00	26	4	49:2	380	48.5	1440	650	8	13	20
IGD39-160P5-13 mm	1600	0.50	11	6	59:1	380	25	900	650	8	13	20
IGD39-161P0-13 mm	1600	1.00	18.5	6	59:2	380	39	900	650	8	13	20
IGD39-161P7-13 mm	1600	1.75	26	4	57:2	380	48.5	1440	650	8	13	20
IGD39-162P0-13 mm	1600	2.00	30	4	49:2	380	55.5	1440	650	8	13	20

Data are subject to change without prior notice.