

# IGD21

## Geared Traction Machine

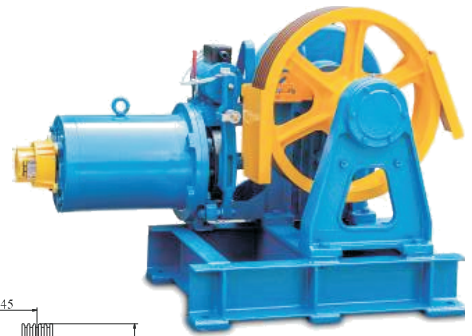

Maximum Full Load Mass: 6,000 KG  
 Brake Coils: Pick/Hold Voltage : 110/67 VDC  
 Pick/Hold Current : 1.5/0.92 A  
 Estimated Weight : 580 KG

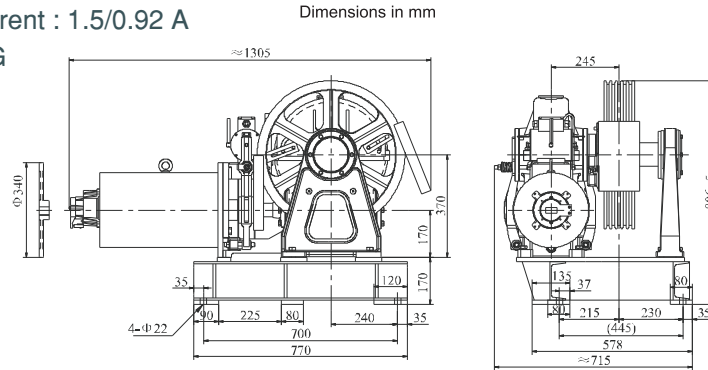

Part Number	Capacity (KG)	Speed (M/S)	Motor (KW)	Pole	Gear Ratio	Power Source (VAC)	Current (A)	Motor Speed (RPM)	Sheave Spec (mm)			
									Dia	Rope#	o Pitch	
IGD21-61P0-13 mm	680	1.00	5.5	4	75:2	380	11.5	1360	530	4	13	20
IGD21-61P7-13 mm	680	1.75	8.5	4	47:2	380	17	1465	530	4	13	20
IGD21-62P0-13 mm	680	2.00	11	4	61:3	380	21.5	1465	530	4	13	20
IGD21-80P5-13 mm	884	0.50	5.5	6	53:1	380	12	960	530	5	13	20
IGD21-81P0-13 mm	884	1.00	8.5	4	75:2	380	17	1360	530	5	13	20
IGD21-81P7-13 mm	884	1.75	11	4	47:2	380	21.5	1465	530	5	13	20
IGD21-82P0-13 mm	884	2.00	11	4	61:3	380	21.5	1465	530	5	13	20
IGD21-100P5-13 mm	1020	0.50	5.5	6	53:1	380	12	960	530	5	13	20
IGD21-101P0-13 mm	1020	1.00	8.5	4	75:2	380	17	1360	530	5	13	20
IGD21-101P7-13 mm	1020	1.75	15	4	47:2	380	29	1465	530	5	13	20
IGD21-102P0-13 mm	1020	2.00	15	4	61:3	380	29	1465	530	6	13	20

Data are subject to change without prior notice.