



# IGD00

## Geared Traction Machine

Maximum Full Load Mass: 1800 KG

Brake Coils: Pick/Hold Voltage : 110/67 VDC

Pick/Hold Current : 1.4/0.85 A

Estimated Weight : 155 KG

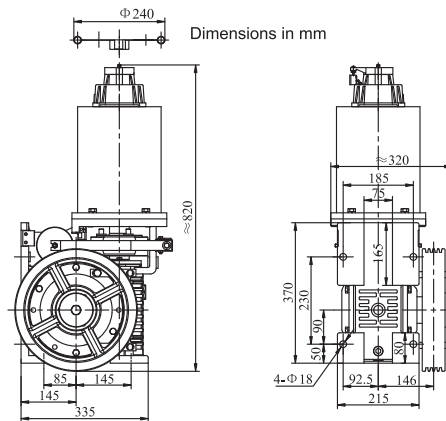

Part Number	Capacity (KG)	Speed (M/S)	Motor (KW)	Pole	Gear Ratio	Power Source (VAC)	Current (A)	Motor Speed (RPM)	Sheave Spec (mm)			
									Dia	Rope#	Ø Pitch	
IGD00-31P0 - 8 mm	320	1.00	3.5	4	45:2	380	7.5	1440	320	4	8	12

Data are subject to change without prior notice.

